

NOTES:

① MAT'L: COPPER (STOCK TKN $\frac{.028}{.71}$)
 PLATING: ELECTRO-TIN (.0003 MIN.)

FILE NO. AA-CD-105-02

STUD SIZES: ($\pm .005$)

- 02 = .094
- 04 = .119
- 06 = .146
- 08 = .173
- 10 = .198
- 14 = .265
- 56 = .328
- 38 = .390

"UL" LISTING *E32244
 "CSA" LISTING #18689

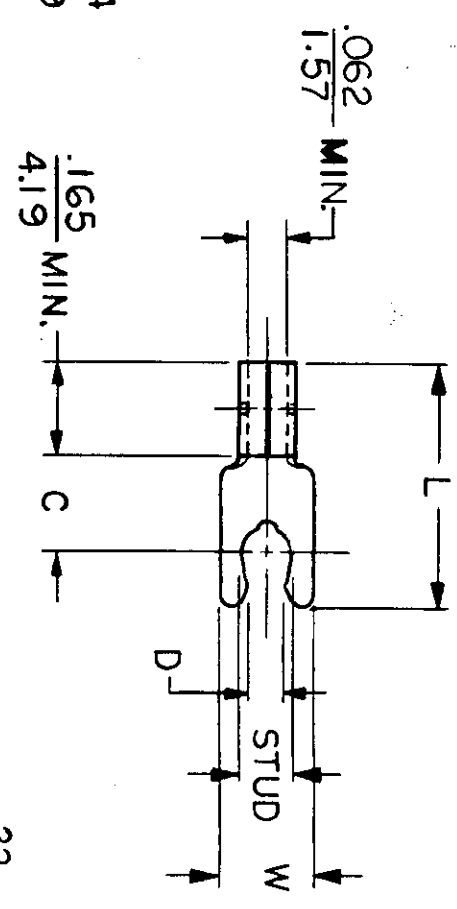

ALL DIMENSIONS = $\frac{\text{INCHES}}{\text{MM}}$

WIRE SIZE: 22 - 18 AWG
 $.25 - 1.5 \text{ MM}^2$

PART NUMBER	"W" $\pm .010$	"C" MIN.	"L" MAX.	"D" $\pm .005$	AVAILABLE STUD SIZES	DIMENSIONAL TOLERANCES UNLESS OTHERWISE SPECIFIED		REFERENCE	SCALE:	NTS	DATE	TITLE:	DWG. NO.	CUSTOMER DWG.
						FRAC.	DEC.							
AA-1704-	$\frac{.250}{6.35}$	$\frac{.230}{5.84}$	$\frac{.585}{14.86}$	$\frac{.105}{2.67}$	05 ($\frac{.127 \pm .005}{3.23}$ DIA.)						10-17-84	SNAP SPADE SHORT TONGUE TERMINAL KRIMPITE 100-SERIES	A	
AA-1704-	$\frac{.250}{6.35}$	$\frac{.230}{5.84}$	$\frac{.585}{14.86}$	$\frac{.114}{2.90}$	06						10-18-84			
AA-1705-	$\frac{.375}{9.53}$	$\frac{.261}{6.63}$	$\frac{.646}{16.41}$	$\frac{.139}{3.53}$	08									
AA-1706-	$\frac{.406}{10.31}$	$\frac{.261}{6.63}$	$\frac{.694}{17.63}$	$\frac{.156}{3.96}$	10									

