

## Crimp Type Straight Cable Termination for Flexible Cable

1. Identify connector parts. (2 piece parts)
2. Strip cable to dimensions shown. Do not nick braid or center conductor. A wire stripper of correct size is recommended for this step. Twist stranded center conductor into tight bundle and tin. Slide crimp sleeve onto cable as shown.
3. Flare braid and slide cable into body making certain that the cable insulation is flush with bottom of connector.
4. Arrange braid uniformly around crimp stem. Slide crimp sleeve over braid and crimp securely using recommended crimp tool.

Cable Group	Part No.	"A"	Crimp Hex
RG-178/U, 196	142-0002-221/226	.259 (6.58)	.105 (2.67)
RG-316/U, 161, 174, 179, 187, 188	142-0003-201/206	.312 (7.92)	.128 (3.25)
	142-0003-231/236	.259 (6.58)	.128 (3.25)
	142-0003-241/246	.259 (6.58)	.128 (3.25)
RG-316 DS, 188 DS	142-0004-201/206	.312 (7.92)	.151 (3.83)
	142-0004-211/216	.259 (6.58)	.151 (3.83)
	142-0004-221/226	.259 (6.58)	.151 (3.83)

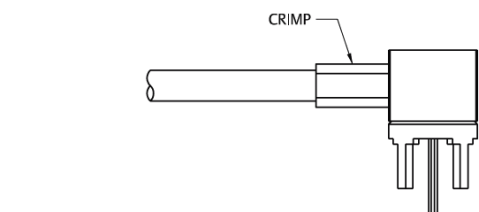
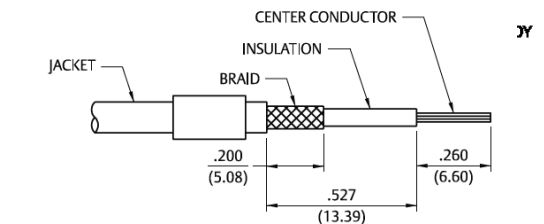
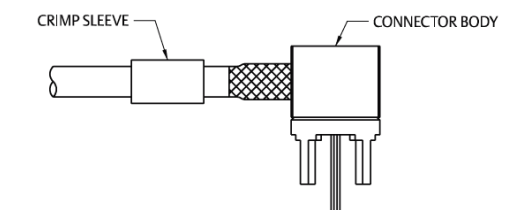
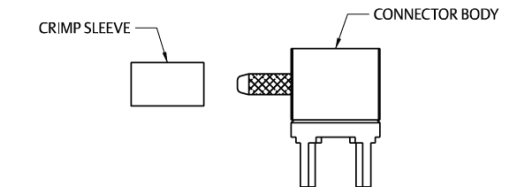
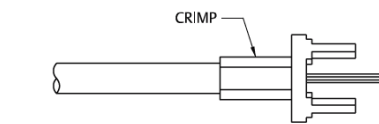
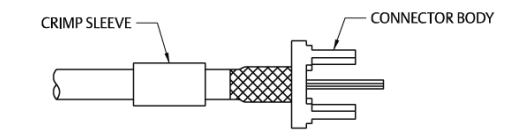
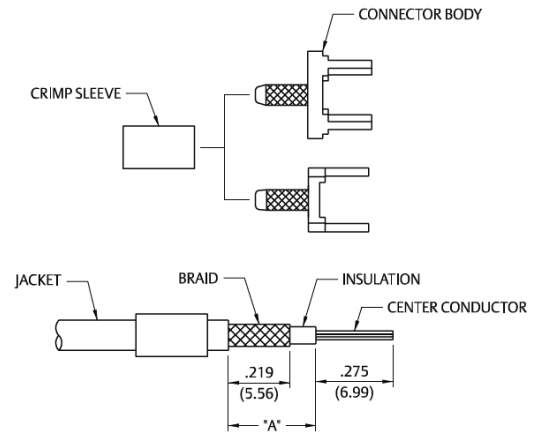

## Crimp Type Right Angle Cable Termination for Flexible Cable

1. Identify connector parts. (2 piece parts)
2. Strip cable to dimensions shown. Do not nick braid or center conductor. A wire stripper of correct size is recommended for this step. Twist stranded center conductor into tight bundle and tin. Slide crimp sleeve onto cable as shown.
3. Flare braid and slide cable into body making certain that the cable insulation is flush with bottom of connector body.
4. Arrange braid uniformly around crimp stem. Slide crimp sleeve over braid and crimp securely using recommended crimp tool.

Cable Group	Part No.	Crimp Hex
RG-316/U, 161, 174, 179, 187, 188	142-0003-301/306	.128 (3.25)
RG-316 DS, 188 DS	142-0004-301/306	.151 (3.83)