

PRE - ASSEMBLY INSTRUCTIONS:

Caution: Check gasket on top of base unit for damage before assembly. If cut or torn, contact Hammond Manufacturing for immediate replacement.

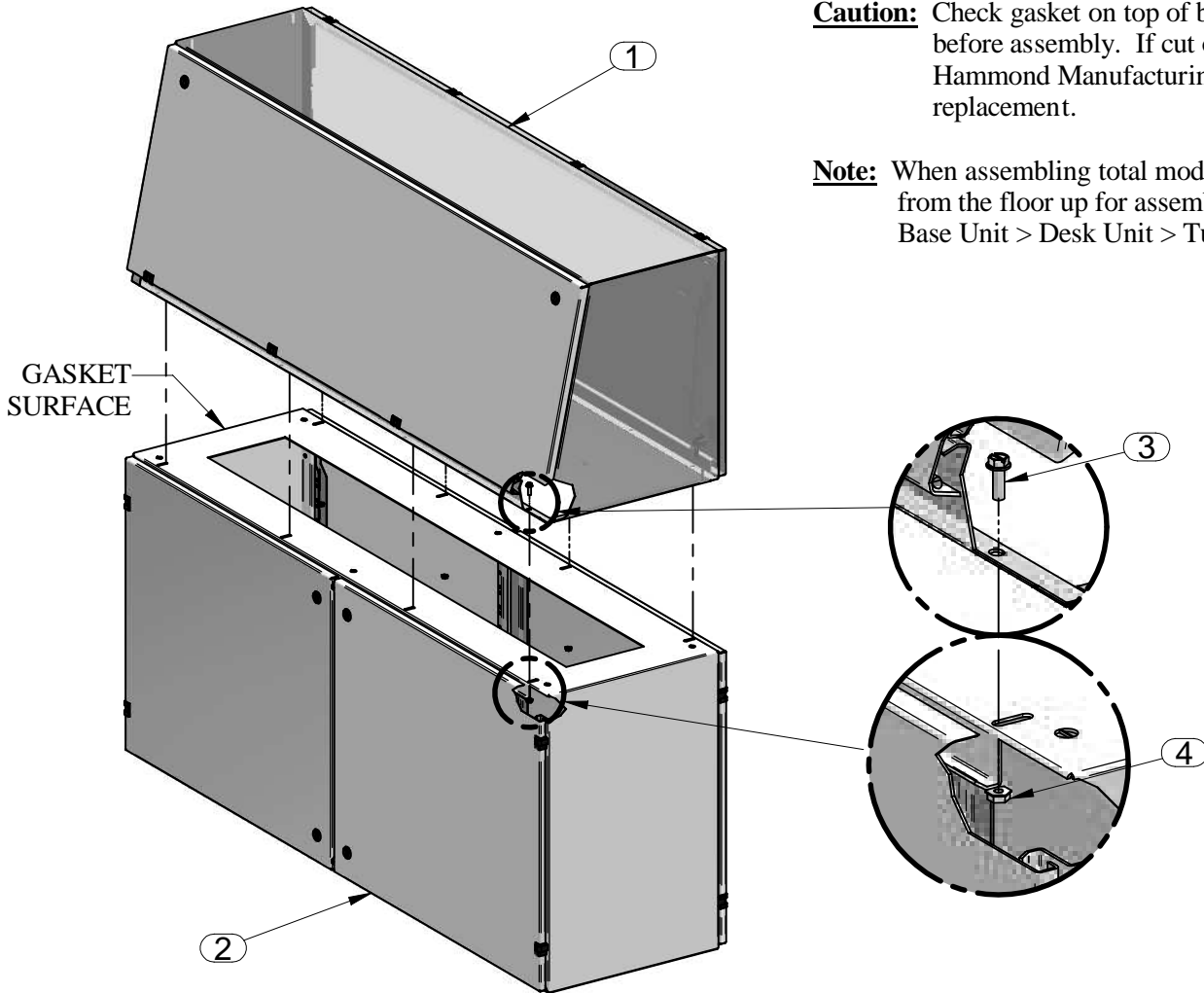

Note: When assembling total modular system build from the floor up for assembly ease. Plinth > Base Unit > Desk Unit > Turret



ASSEMBLY INSTRUCTIONS:

- A) Open or remove doors for ease of assembly. This will allow for visual alignment of mating parts. Remove gasket from bottom of turret (item 1).
- B) Align turret over top opening in base unit. Side edges of turret and base are to be flush
- C) Front and rear slots in turret bottom are to be aligned with mounting slots on base top (item 2).
- D) Once the turret is seated properly on the base assemble using 1/4-20 x .75 hex hd. screws and 1/4-20 KEP nuts (item 3 & 4) provided. Torque screws and nuts to 115 in/lbs

PARTS LIST		
ITEM No.	DESCRIPTION	QTY
1	TURRET UNIT	1
2	BASE UNIT	1
3	1/4-20 X 3/4 HEX CAP SCREW	4, 6 or 8
4	1/4-20 KEP NUT	4, 6 or 8

TOOL BOX 	3/8, 7/16" Socket Wrench 	3/8, 7/16 Open Wrench 
------------------------------------------------------------------------------------------------	-----------------------------------------------------------------------------------------------------------------	--------------------------------------------------------------------------------------------------------------

