

4

3

2

1

THIS DRAWING IS UNPUBLISHED. RELEASED FOR PUBLICATION, 19 .  
 © COPYRIGHT 19 BY AMP INCORPORATED. ALL RIGHTS RESERVED.

LOC	DIST	REVISIONS					
		P	LTR	DESCRIPTION	DATE	DWN	APVD
G	14		B	REDRAWN PER 0720-0470-95	23JAN95	LO	ME

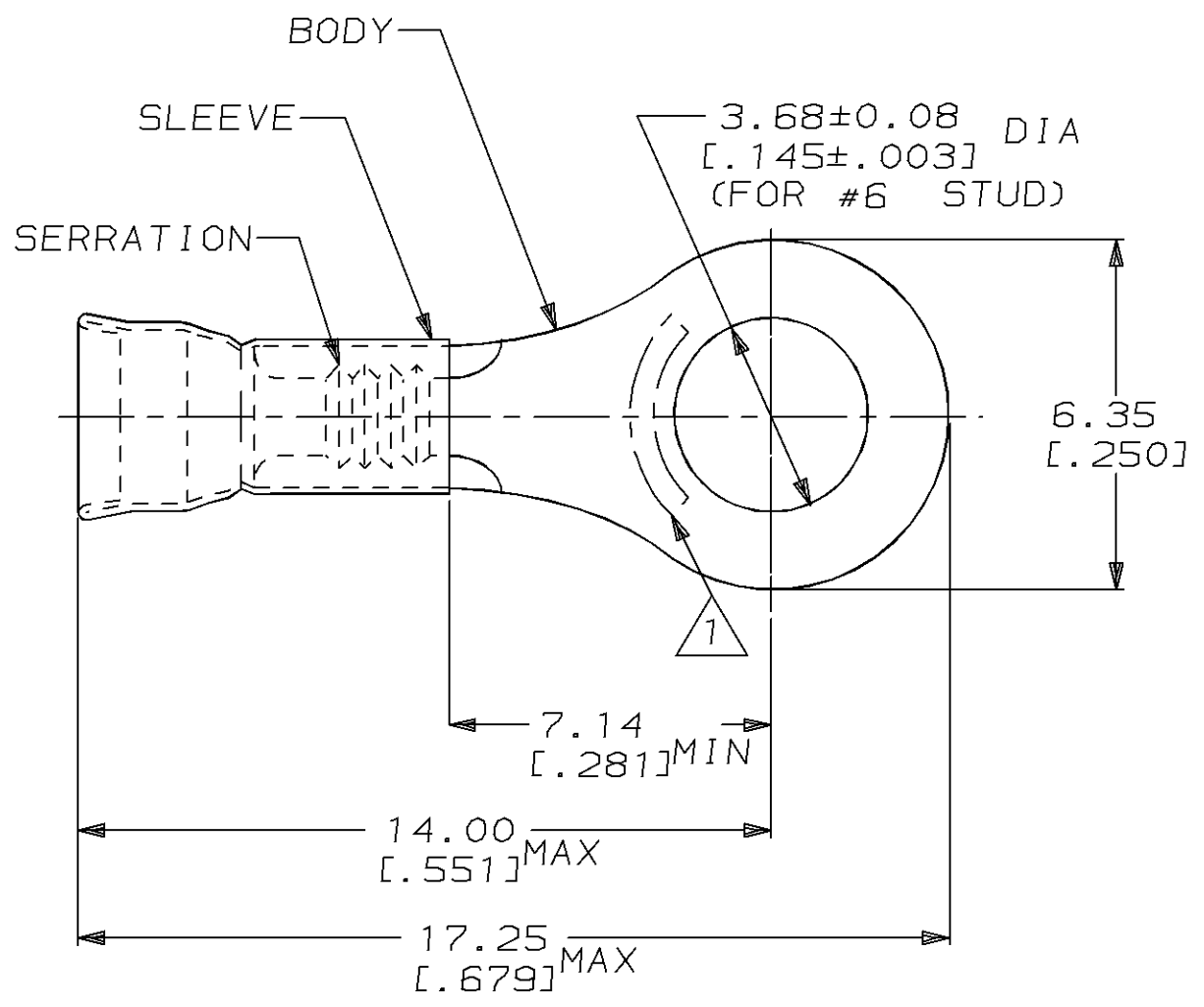

△ 1 STAMP AMP LOCATE APPROX AS SHOWN

- 2. WIRE INSUL DIA, 1.27-2.08 [.050-.082]
- 3. TONGUE MATL THK, 0.46±0.05 [.018±.002]

5000	ON TAPE, REEL	2-32861-2
1000	LOOSE PIECE	32861
QTY	PACKAGE TYPE	PART NO

AMP INCORPORATED CUSTOMER SERVICE SYSTEM	
FOR ADDITIONAL PRODUCT INFORMATION OR COPIES OF DRAWINGS AND TECHNICAL DOCUMENTS	PRODUCT INFORMATION CENTER 1-800-522-6752
FOR APPLICATION TOOLING INFORMATION	TOOLING ASSISTANCE CENTER 1-800-722-1111
FOR ORDER ENTRY	1-800-526-5142

MAX RECOMMENDED OPERATING  
TEMPERATURE:  
-

VOLTAGE RATING:  
-

CIRCULAR MIL AREA:  
0.10mm<sup>2</sup>-0.41mm<sup>2</sup> [202-810]

STRANDED WIRE

THIS DRAWING IS A CONTROLLED DOCUMENT FOR AMP INCORPORATED.  
IT IS SUBJECT TO CHANGE AND THE CONTROLLING ENGINEERING  
ORGANIZATION SHOULD BE CONTACTED FOR THE LATEST REVISION.

DIMENSIONS:	TOLERANCES UNLESS OTHERWISE SPECIFIED:
mm [in]	
	0 PLC ±-
	1 PLC ±-
	2 PLC ±0.20 [.008]
	3 PLC ±-
	4 PLC ±-
	ANGLES ±-

MATERIAL  
BODY, CU, SLV, CU PER  
ASTM B152

FINISH  
TIN PLATE  
PER MIL-T-10727

DWN	L OLMEDA	23JAN95
CHK	M ELLIS	23JAN95
APVD	S BORTNER	23JAN95
PRODUCT SPEC	-	-
APPLICATION SPEC	-	-
WEIGHT	-	-
CUSTOMER DRAWING		

**AMP** AMP Incorporated  
Harrisburg, PA 17105-3608

NAME  
TERMINAL, RING,  
DIAMOND GRIP,  
WIRE SIZE, 26-22 AWG

SIZE	A3	CAGE CODE	00779	DRAWING NO	C-32861
SCALE	6:1	SHEET	1 OF 1	REV	B