

## Sample Kit Contents

KEMET Part Number	Case Size	Capacitance	Cap Tolerance	Rated Voltage	T Thickness	Dielectric	Quantity
	EIA/Metric		%	VDC	mm		
C1206C222K2RACTU	1206/3216	2200 pF	±10	200	0.78 ±0.10	X7R	50
C1206C104K5RACTU	1206/3216	0.1 µF	±10	50	0.78 ±0.10	X7R	50
C1206C154K5RACTU	1206/3216	0.15 µF	±10	50	0.90 ±0.10	X7R	50
C1206C224K5RACTU	1206/3216	0.22 µF	±10	50	0.90 ±0.10	X7R	50
C1206C334K5RACTU	1206/3216	0.33 µF	±10	50	0.90 ±0.10	X7R	50
C1206C474K3RACTU	1206/3216	0.47 µF	±10	25	0.90 ±0.10	X7R	50
C1206C105K3RACTU	1206/3216	1 µF	±10	25	1.60 ±0.20	X7R	50
C1206C225K5RACTU	1206/3216	2.2 µF	±10	50	1.60 ±0.20	X7R	50
C1206C106K4RACTU	1206/3216	10 µF	±10	16	1.60 ±0.20	X7R	50
C1206C225K4PACTU	1206/3216	2.2 µF	±10	16	0.90 ±0.10	X5R	50
C1206C335K3PACTU	1206/3216	3.3 µF	±10	25	1.60 ±0.20	X5R	50
C1206C475K3PACTU	1206/3216	4.7 µF	±10	25	1.60 ±0.20	X5R	50
C1206C106K4PACTU	1206/3216	10 µF	±10	16	1.60 ±0.20	X5R	50
C1206C100C2GACTU	1206/3216	10 pF	±0.25	200	0.78 ±0.10	C0G	50
C1206C220C2GACTU	1206/3216	22 pF	±0.25	200	0.78 ±0.10	C0G	50
C1206C330D2GACTU	1206/3216	33 pF	±0.5	200	0.78 ±0.10	C0G	50
C1206C470D2GACTU	1206/3216	47 pF	±0.5	200	0.78 ±0.10	C0G	50
C1206C101J1GACTU	1206/3216	100 pF	±5	100	0.78 ±0.10	C0G	50
C1206C221J1GACTU	1206/3216	220 pF	±5	100	0.78 ±0.10	C0G	50
C1206C471J1GACTU	1206/3216	470 pF	±5	100	0.78 ±0.10	C0G	50
C1206C102J1GACTU	1206/3216	1000 pF	±5	100	0.78 ±0.10	C0G	50
C1206C222K1GACTU	1206/3216	2200 pF	±10	100	1.10 ±0.10	C0G	50
C1206C472K5GACTU	1206/3216	4700 pF	±10	50	0.90 ±0.10	C0G	50

## Dimensions – Millimeters (Inches)

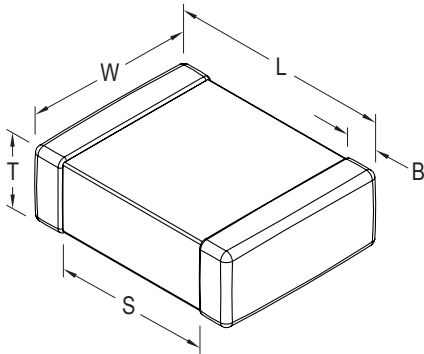

Case Size (in.)	Case Size (mm)	L Length	W Width	T Thickness	B Bandwidth	Mounting Technique
1206	3216	3.20 (0.126) ±0.20 (0.008)	1.60 (0.063) ±0.20 (0.008)	See Table Above	0.50 (0.02) ±0.25 (0.010)	Solder Wave or Solder Reflow